

- L2 is recognized by antibodies, directed against the C-terminal microbody protein targeting signal SKL. *Eur J Cell Biol* **61**: 86–91.
- Marvin-Sikkema, F.D., Driessen, A.J., Gottschal, J.C., and Prins, R.A. (1994) Metabolic energy generation in hydrogenosomes of the anaerobic fungus *Neocallimastix*: Evidence for a functional relationship with mitochondria. *Mycol Res* **98**: 205–212.
- Mewes, H.W., Albermann, K., Bahr, M., Frishman, D., Gleissner, A., Hani, J., et al. (1997) Overview of the yeast genome. *Nature* **387**: 7–65.
- Müller, M. (1993) The hydrogenosome. *J Gen Microbiol* **139**: 2879–2889.
- O'Fallon, J.V., Wright, Jr, R.W., and Calza, R.E. (1991) Glucose metabolic pathways in the anaerobic rumen fungus *Neocallimastix frontalis* EB188. *Biochem J* **274**: 595–599.
- Ohno, S. (1970) *Evolution by Gene Duplication*. Berlin: Springer.
- Plaga, W., Frank, R., and Knappe, J. (1988) Catalytic-site mapping of pyruvate formate lyase. Hypophosphite reaction on the acetyl-enzyme intermediate affords carbon-phosphorus bond synthesis (1-hydroxyethylphosphonate). *Eur J Biochem* **178**: 445–450.
- Ragan, M.A., and Chapman, D.J. (1978) *A Biochemical Phylogeny of the Protists*. New York: Academic Press.
- Reizer, J., Reizer, A., and Saier, Jr, M.H. (1995) Novel phosphotransferase system genes revealed by bacterial genome analysis – a gene cluster encoding a unique Enzyme I and the proteins of a fructose-like permease system. *Microbiology* **141**: 961–971.
- Rödel, W., Plaga, W., Frank, R., and Knappe, J. (1988) Primary structures of *Escherichia coli* pyruvate formate-lyase and pyruvate-formate-lyase-activating enzyme deduced from the DNA nucleotide sequences. *Eur J Biochem* **177**: 153–158.
- Sogin, M. (1991) Early evolution and the origin of eukaryotes. *Curr Opin Genet Dev* **1**: 457–463.
- Steinbüchel, A., and Müller, M. (1986) Anaerobic pyruvate metabolism of *Trichomonas foetus* and *Trichomonas vaginalis* hydrogenosomes. *Mol Biochem Parasitol* **20**: 57–65.
- Syvanen, M. (1994). Horizontal gene transfer: evidence and possible consequences. *Annu Rev Genet* **28**: 237–261.
- Teunissen, M.J., Op den Camp, H.J., Orpin, C.G., Huis in't Veld, J.H., and Vogels, G.D. (1991) Comparison of growth characteristics of anaerobic fungi isolated from ruminant and non-ruminant herbivores during cultivation in a defined medium. *J Gen Microbiol* **137**: 1401–1408.
- Trinci, A.P., Davies, D.R., Gull, K., Lawrence, M.I., Bonde Nielsen, B., Rickers, A., and Theodorou, M.K. (1994) Anaerobic fungi in herbivorous animals. *Mycol Res* **98**: 129–152.
- Wagner, A.F., Frey, M., Neugebauer, F.A., Schafer, W., and Knappe, J. (1992) The free radical in pyruvate formate-lyase is located on glycine-734. *Proc Natl Acad Sci USA* **89**: 996–1000.
- Weidner, G., and Sawers, G. (1996) Molecular characterization of the genes encoding pyruvate formate-lyase and its activating enzyme of *Clostridium pasteurianum*. *J Bacteriol* **178**: 2440–2444.
- Yamamoto, Y., Sato, Y., Takahashi-Abbe, S., Abbe, K., Yamada, T., and Kizaki, H. (1996) Cloning and sequence analysis of the *pfl* gene encoding pyruvate formate-lyase from *Streptococcus mutans*. *Infect Immun* **64**: 385–391.
- Yarlett, N., Lloyd, D., and Williams, A.G. (1982) Respiration of the rumen ciliate *Dasytricha ruminantium* Schuberg. *Biochem J* **206**: 259–266.
- Yarlett, N., Orpin, C.G., Munn, E.A., Yarlett, N.C., and Greenwood, C.A. (1986) Hydrogenosomes in the rumen fungus *Neocallimastix patriciarum*. *Biochem J* **236**: 729–739.

- Bowman, B.H., Taylor, J.W., Brownlee, A.G., Lee, J., Lu, S.D., and White, T.J. (1992) Molecular evolution of the fungi: relationship of the *Basidiomycetes*, *Ascomycetes*, and *Chytridiomycetes*. *Mol Biol Evol* **9**: 285–296.
- Brondijk, T.H., Durand, R., van der Giezen, M., Gottschal, J.C., Prins, R.A., and Fevre, M. (1996) scsB, a cDNA encoding the hydrogenosomal beta subunit of succinyl-CoA synthetase from the anaerobic fungus *Neocallimastix frontalis*. *Mol Gen Genet* **253**: 315–323.
- Brownlee, A.G. (1994) The nucleic acids of anaerobic fungi. In *Anaerobic Fungi Biology, Ecology, and Function*. Mountfort, D.O., and Orpin, C.G. (eds). New York: Marcel Dekker, pp. 241–256.
- Chirgwin, J.M., Przybyla, A.E., MacDonald, R.J., and Rutter, W.J. (1979) Isolation of biologically active ribonucleic acid from sources enriched in ribonuclease. *Biochemistry* **18**: 5294–5299.
- Conradt, H., Hohmann-Berger, M., Hohmann, H.P., Blaschkowski, H.P., and Knappe, J. (1984) Pyruvate formate-lyase (inactive form) and pyruvate formate-lyase activating enzyme of *Escherichia coli*: isolation and structural properties. *Arch Biochem Biophys* **228**: 133–142.
- Coombs, G.H., and Hackstein, J.H.P. (1995) Anaerobic protists and anaerobic ecosystems. In *Protistological Actualities: Proceedings of the Second European Congress of Protistology, Clermont-Ferrand, France, 1995*. Brugerolle, G., and Mignot, J.-P. (eds). Clermont-Ferrand, France: Université Blaise Pascal, pp. 90–101.
- Devereux, J., Haeberli, P., and Smithies, O. (1984) A comprehensive set of sequence analysis programs for the VAX. *Nucleic Acids Res* **12**: 387–395.
- Dore, J., and Stahl, D.A. (1991) Phylogeny of anaerobic rumen *Chytridiomycetes* inferred from small subunit ribosomal RNA sequence comparisons. *Can J Botany* **69**: 1964–1971.
- Dumont, F., Joris, B., Gumusboga, A., Bruyninx, M., and Loppes, R. (1993) Isolation and characterization of cDNA sequences controlled by inorganic phosphate in *Chlamydomonas reinhardtii*. *Plant Sci* **89**: 55–67.
- Durand, R., Fischer, M., Rasclé, C., and Fevre, M. (1995) *Neocallimastix frontalis* enolase gene, enol: first report of an intron in an anaerobic fungus. *Microbiology* **141**: 1301–1308.
- Elgersma, Y., Kwast, L., Klein, A., Voorn-Brouwer, T., van den Berg, M., Metzger, B., et al. (1996) The SH3 domain of the *Saccharomyces cerevisiae* peroxisomal membrane protein Pex13p functions as a docking site for Pex5p, a mobile receptor for the import PTS1-containing proteins. *J Cell Biol* **135**: 97–109.
- Embley, T.M., Finlay, B.J., Dyal, P.L., Hirt, R.P., Wilkinson, M., and Williams, A.G. (1995) Multiple origins of anaerobic ciliates with hydrogenosomes within the radiation of aerobic ciliates. *Proc R Soc Lond B Biol Sci* **262**: 87–93.
- Fanutti, C., Panyi, T., Black, G.W., Hazlewood, G.P., and Gilbert, H.J. (1995) The conserved non-catalytic 40-residue sequence in cellulases and hemicellulases from anaerobic fungi functions as a protein docking domain. *J Biol Chem* **270**: 29314–29322.
- Felsenstein, J. (1993) PHYLIP (Phylogeny Inference Package). Seattle, USA: Department of Genetics, University of Washington.
- Fleischmann, R.D., Adams, M.D., White, O., Clayton, R.A., Kirkness, E.F., Kerlavage, A.R., et al. (1995) Whole-genome random sequencing and assembly of *Haemophilus influenzae* Rd. *Science* **269**: 496–512.
- van der Giezen, M., Rechinger, K.B., Svendsen, I., Durand, R., Hirt, R.P., Fevre, M., et al. (1997) A mitochondrial-like targeting signal on the hydrogenosomal malic enzyme from the anaerobic fungus *Neocallimastix frontalis*: support for the hypothesis that hydrogenosomes are modified mitochondria. *Mol Microbiol* **23**: 11–21.
- van der Giezen, M., Kiel, J.A.K.W., Sjollem, K.A., and Prins, R.A. (1998) The hydrogenosomal malic enzyme from the anaerobic fungus *Neocallimastix frontalis* is targeted to mitochondria of the methylotrophic yeast *Hansenula polymorpha*. *Curr Genet* **33**: 131–135.
- von Heijne, G., Steppuhn, J., and Herrmann, R.G. (1989) Domain structure of mitochondrial and chloroplast targeting peptides. *Eur J Biochem* **180**: 535–545.
- Hendrick, J.P., Hodges, P.E., and Rosenberg, L.E. (1989) Survey of amino-terminal proteolytic cleavage sites in mitochondrial precursor proteins: leader peptides cleaved by two matrix proteases share a three-amino acid motif. *Proc Natl Acad Sci USA* **86**: 4056–4060.
- Hesslinger, C., Fairhurst, S.A., and Sawers, G. (1998) Novel keto acid formate-lyase and propionate kinase enzymes are components of an anaerobic pathway in *Escherichia coli* that degrades L-threonine to propionate. *Mol Microbiol* **27**: 477–492.
- Knappe, J., and Sawers, G. (1990) A radical chemical route to acetyl-CoA: the anaerobically induced pyruvate formate-lyase system of *Escherichia coli*. *FEMS Microbiol Rev* **6**: 383–398.
- Knoll, A.H. (1992) The early evolution of eukaryotes: a geological perspective. *Science* **256**: 622–627.
- Li, J., and Heath, I.B. (1992) The phylogenetic relationships of the anaerobic chytridiomycetous gut fungi (*Neocallimasticeae*) and the chytridiomycota. I. Cladistic analysis of rRNA sequences. *Can J Botany* **70**: 1738–1746.
- Li, J., Heath, I.B., and Packer, L. (1993) The phylogenetic relationships of the anaerobic chytridiomycetous gut fungi (*Neocallimasticeae*) and the chytridiomycota. II. Cladistic analysis of structural data and description of *Neocallimasticales* ord. nov. *Can J Botany* **71**: 393–407.
- Martin, W., and Herrmann, R.G. (1998). Gene transfer from organelles to the nucleus: how much, what happens, and why? *Plant Physiol* **118**: 9–17.
- Martin, W., and Müller, M. (1998) The hydrogen hypothesis for the first eukaryote. *Nature* **392**: 37–41.
- Marvin-Sikkema, F.D., Richardson, A.J., Stewart, C.S., Gottschal, J.C., and Prins, R.A. (1990) Influence of hydrogen-consuming bacteria on cellulose degradation by anaerobic fungi. *Appl Environ Microbiol* **56**: 3793–3797.
- Marvin-Sikkema, F.D., Lahpor, G.A., Kraak, M.N., Gottschal, J.C., and Prins, R.A. (1992) Characterization of an anaerobic fungus from llama faeces. *J Gen Microbiol* **138**: 2235–2241.
- Marvin-Sikkema, F.D., Pedro Gomes, T.M., Grivet, J.P., Gottschal, J.C., and Prins, R.A. (1993a) Characterization of hydrogenosomes and their role in glucose metabolism of *Neocallimastix* sp. L2. *Arch Microbiol* **160**: 388–396.
- Marvin-Sikkema, F.D., Kraak, M.N., Veenhuis, M., Gottschal, J.C., and Prins, R.A. (1993b) The hydrogenosomal enzyme hydrogenase from the anaerobic fungus *Neocallimastix* sp.

poly(A)<sup>+</sup> RNA, an mRNA purification kit (Pharmacia) was used. RNA was separated on 1.2% agarose–formaldehyde gels. Gels were blotted to Hybond N<sup>+</sup> membrane (Amersham). DNA probes were labelled by PCR with  $\alpha$ -[<sup>32</sup>P]-dATP. To make probes from the pPFLa12 and pPFLh115 cDNA clones, the universal M13 forward and reverse primers were used for PCR. To generate probes specific for the 'long'- or 'short'-type PFL, PCR was performed with the M13 reverse primer and the primer PFLrev4 using the clones pL1 ('long'-type PFL) or pS2 ('short'-type PFL) as a template. Hybridization was performed in 0.5 M sodium phosphate buffer, pH 7.0, 7% SDS, 1% BSA and 1 mM EDTA at 60°C. Filters were washed stringently with 50 mM sodium phosphate buffer, pH 7.0, and 0.5% SDS at 60°C.

#### Subcellular fractionation and Western blotting

Hydrogenosomal and cytosolic fractions were prepared from *Piromyces* sp. E2 biomass, essentially as described by Marvin-Sikkema *et al.* (1993a) with the following modification: the potassium phosphate (KPi) buffer in the homogenization medium was substituted for 20 mM K-HEPES buffer, pH 7.4. The hydrogenosomal fraction was subfractionated by carbonate extraction as described previously by Elgersma *et al.* (1996). Proteins were separated on 7.5% polyacrylamide gels with 0.1% SDS and were blotted to polyvinylidenedifluoride membrane by semidry transfer (Bio-Rad) according to the manufacturer's protocol. Rabbit antiserum raised against PFL protein of *Escherichia coli* was kindly provided by Dr D. Kessler. It was used in a dilution of 1:250. Detection was performed using goat anti-rabbit antibodies conjugated to peroxidase (Boehringer Mannheim).

#### Proteinase K protection assay

Isolated hydrogenosomes (about 0.8 mg of protein) were incubated anaerobically (N<sub>2</sub> gas phase) in 1 ml digestion buffer containing: 20 mM K-HEPES, pH 7.4, 250 mM sucrose, 2 mM DTT with proteinase K (0.0, 0.2 and 20.0  $\mu$ g ml<sup>-1</sup>) and detergent (0.1% Triton X-100 and 0.1% deoxycholate) in all possible combinations. After 30 min incubation on ice, the proteinase K digestion was stopped by the addition of 1 ml 15% (w/v) trichloroacetic acid. Protein was recovered by centrifugation.

#### Enzyme assays

To measure PFL activity, 0.5 ml of the cytosolic or hydrogenosomal fraction (0.5 mg protein) was added to 4.5 ml of assay mix, containing: 20 mM K-HEPES, pH 7.5, 2 mM KPi, 100 mM succinate, 5 mM magnesium ADP, 2 mM DTT, 1.3 mM ferriammonium sulphate, 0.12 mM CoA and 30 mM pyruvate. The incubation was stopped after 60 min by heating (5 min, 100°C). Formation of formate was determined with formate dehydrogenase (Boehringer Mannheim). Samples, heated (5 min, 100°C) before addition to the assay mix, were used as controls to correct for internal formate pools. Hypophosphite, a specific inhibitor of PFL activity (Plaga *et al.*, 1988), was added to a final concentration of 10 mM. For enzyme assays with the hydrogenosomal fraction, Triton X-100 was added to a final concentration of 0.2% (v/v) to permeabilize

the organelles. All enzyme assays were performed anaerobically (N<sub>2</sub> gas phase) at 39°C.

#### Analysis of hydrogenosomal fermentation products

Isolated hydrogenosomes were resuspended in 20 mM K-HEPES buffer, pH 7.4, supplemented with 250 mM sucrose and 2 mM DTT. From this suspension, 0.2 ml (about 0.55 mg protein) was added to 2 ml of assay mixture, containing 20 mM K-HEPES buffer, pH 7.4, 250 mM sucrose, 2 mM DTT, 2 mM KPi buffer, 100 mM succinate, 5 mM magnesium ADP, and 5 mM L-malate. Incubations were performed anaerobically (N<sub>2</sub> gas phase) at 39°C in 15 ml vials. Liquid samples were analysed for malate, pyruvate, acetate and formate with the help of Test Combinations purchased from Boehringer Mannheim. Gas samples were analysed by gas chromatography for the determination of the hydrogen concentration (Teunissen *et al.*, 1991).

#### Acknowledgements

We are very grateful to Dr D. Kessler for providing the antiserum against *Escherichia coli* PFL and J. Eygenstein for assisting in DNA sequencing. This work was supported by a grant from The Netherlands Organization for the Advancement of Pure Research (NWO).

#### References

- Adachi, J., and Hasegawa, M. (1992) MOLPHY, version 2.2: programs for molecular phylogenetics. Tokyo: Institute of Statistical Mathematics.
- Akhmanova, A., Voncken, F.G.J., Harhangi, H., Hosea, K.M., Vogels, G.D., and Hackstein, J.H.P. (1998a) Cytosolic enzymes with a mitochondrial ancestry from the anaerobic chytrid *Piromyces* sp. E2. *Mol Microbiol* **30**: 1017–1027.
- Akhmanova, A., Voncken, F., van Alen, T., van Hoek, A., Boxma, B., Vogels, G., *et al.* (1998b) A hydrogenosome with a genome. *Nature* **396**: 527–528.
- Arnau, J., Jorgensen, F., Madsen, S.M., Vrang, A., and Israelson, H. (1997) Cloning, expression, and characterization of the *Lactococcus lactis pfl* gene, encoding pyruvate formate-lyase. *J Bacteriol* **179**: 5884–5891.
- Benchimol, M., Aquino Almeida, J.C., and de Souza, W. (1996a) Further studies on the organization of the hydrogenosome in *Tritrichomonas foetus*. *Tissue Cell* **28**: 287–299.
- Benchimol, M., Johnson, P.J., and de Souza, W. (1996b) Morphogenesis of the hydrogenosome: an ultrastructural study. *Biol Cell* **87**: 197–205.
- Biagini, G.A., Finlay, B.J., and Lloyd, D. (1997) Evolution of the hydrogenosome. *FEMS Microbiol Lett* **155**: 133–140.
- Blattner, F.R., Burland, V., Plunkett, III, G., Sofia, H.J., and Daniels, D.L. (1993) Analysis of the *Escherichia coli* genome. IV. DNA sequence of the region from 89.2 to 92.8 minutes. *Nucleic Acids Res* **21**: 5408–5417.
- Blattner, F.R., Plunkett, III, G., Bloch, C.A., Perna, N.T., Burland, V., Riley, M., *et al.* (1997) The complete genome sequence of *Escherichia coli* K-12. *Science* **277**: 1453–1474.

sp. E2 acquired PFL from a prokaryotic source, perhaps from a *Clostridium*-like eubacterium (Fig. 3). Such a PFL enables the chytrid to avoid the generation of reduction equivalents during the metabolism of pyruvate (Fig. 10). However, the formation (and excretion) of formate and acetate only allows the generation of one ATP molecule by substrate level phosphorylation. Compartmentalization of the pyruvate catabolism, i.e. the evolution of hydrogenosomes, might allow the generation of extra ATP molecules by the generation of a proton motive force.

The presence of PFL instead of PFO in the hydrogenosomes of anaerobic chytrids has at least one obvious consequence, i.e. these hydrogenosomes cannot rely on pyruvate for hydrogen formation (see Marvin-Sikkema *et al.*, 1994; K. Hosea, unpublished). The formation of molecular hydrogen requires reduction equivalents that, in the hydrogenosomes of chytrids, seem to be provided by a hydrogenosomal malic enzyme that catalyses the oxidative decarboxylation of malate to pyruvate (Fig. 10). This also implies that the NAD(P)H that is generated by the hydrogenosomal malic enzyme must be reoxidized by the hydrogenase, either directly or indirectly. For anaerobic chytrids, we do not know yet how NAD(P)H is reoxidized, but recently we were able to provide evidence for a new type of 'iron-only' hydrogenase in anaerobic ciliates that might be capable of binding and reoxidizing NAD(P)H directly (Akhmanova *et al.*, 1998b).

These observations might lead to the conclusion that the presence of PFL in a hydrogenosome is less favourable than a hydrogenosomal PFO because a hydrogenosomal PFL requires import machinery for malate and a hydrogenosomal malic enzyme (Fig. 10). Naturally, we cannot exclude that the presence of PFL in anaerobic chytrids is purely accidental and is due to the particular evolutionary history of the anaerobic chytrids. However, the potential secondary loss of mitochondria (Akhmanova *et al.*, 1998a) and the presence of PFL in both the cytoplasm and the hydrogenosomes of anaerobic chytrids might support a hypothetical scenario for the adaptation of the ancestral, mitochondriate chytrids to anaerobic environments.

Our data suggest that the chytrid PFL has been acquired by lateral gene transfer (Fig. 3). However, lateral gene transfer seems to be a rare event in eukaryotes (Syvanen, 1994), and the assumption of independent acquisitions of either two different PFLs or one PFL and one PFO appear unlikely. The generation of hydrogenosomal *pfl* genes by duplication of the genes encoding the cytoplasmic isoforms seems to be the most straightforward way to evolve a hydrogenosomal PFL because gene duplication is an important evolutionary process in eukaryotes, and is more frequent than lateral gene transfer or the transfer of organellar genes to the nucleus (Ohno, 1970; Mewes *et al.*, 1997; Martin and Herrmann, 1998). Notably, the presence of multiple copies of PFL genes provides direct evidence

for gene duplications in the chytrids (Figs 2, 4 and 6). Therefore, a scenario that assumes: (1) an acquisition of a cytoplasmic PFL by lateral gene transfer; (2) gene duplication events that create the multigene family of PFLs; and (3) compartmentalization of a subfamily of PFLs in the hydrogenosomes might provide an explanation as to why PFL and not PFO is present in the hydrogenosomes of anaerobic chytrids. Consequently, the evolution of PFL-possessing hydrogenosomes by gene duplication and compartmentalization might be a possible consequence of the adaptation of chytrids to anoxic environments, after the loss of their ancestral mitochondria and an acquisition of PFL by lateral gene transfer.

## Experimental procedures

### Organisms and growth conditions

The axenic cultures of the chytrids *Piromyces* sp. E2 and *Neocallimastix* sp. L2 were grown anaerobically (N<sub>2</sub>/CO<sub>2</sub> gas phase) in medium M2, supplemented with 0.5% fructose (Marvin-Sikkema *et al.*, 1990; Teunissen *et al.*, 1991). Biomass was harvested after 40–48 h of growth at 39°C.

### Random screening of the cDNA library and sequence analysis

The *Piromyces* sp. E2 cDNA library in the vector λ ZAPII was constructed as described previously (Akhmanova *et al.*, 1998a). cDNA clones were picked at random and were sequenced with the M13 reverse primer to determine the sequence of the 5' part of these cDNAs. The sequences of interesting cDNAs were completed by generating shorter subclones in pUC18 and by using internal sequencing primers. To obtain 5' terminal cDNA sequences, RACE-PCR was performed with *Piromyces* sp. E2 cDNA ligated into the λ ZAPII vector. The used RACE-PCR primers are: the universal M13 reverse primer; PFLrev1, 5'-GTCTTGGTAACTAAGG-TACGAC-3'; PFLrev2, 5'-TA(AG)TCACCAATAATACGAC-CACG-3'; PFLrev3, 5'-TCAAGGTAACCTGGCTTGTG-3'; PFLrev4, 5'-AGAACCATCACCTTCGTATG-3' (see Fig. 1). The resulting RACE-PCR products were subcloned into pCR 2.1 (Invitrogen) and were sequenced. Sequencing was performed with the ABI Prism Model 310 automatic sequencer using a dRhodamine terminator cycle sequencing ready reaction DNA sequencing kit (Perkin Elmer Applied Biosystems). Sequences were analysed with the GCG Sequence Analysis package (Devereux *et al.*, 1984). Phylogenetic analysis was performed with the programs PHYLIP V3.5c (Felsenstein, 1993) and PROTML (Adachi and Hasegawa, 1992).

### Southern and Northern blotting

Genomic DNA was prepared from *Piromyces* sp. E2 biomass according to the protocol of Brownlee (1994). DNA digested with different restriction enzymes was separated on 0.7% agarose gels. Total RNA was prepared by the guanidinium chloride method (Chirgwin *et al.*, 1979). For preparation of

the hydrogenosome is circumstantial (Fig. 7). However, it has been shown that similar, albeit considerably shorter, N-terminal leader sequences have been described for other hydrogenosomal enzymes such as malic enzyme and succinyl-CoA synthetase (Brondijk *et al.*, 1996; van der Giezen *et al.*, 1997). These N-terminal extensions are cleaved upon import into the hydrogenosomes (van der Giezen *et al.*, 1997; 1998).

The fermentation pattern measured after incubation of isolated hydrogenosomes with malate as a substrate is in agreement with the assumption that the main carbon flow in the hydrogenosomes of chytrids occurs via PFL (Fig. 9). The formation of equimolar amounts of formate and acetate definitely excludes a significant PFO activity being present in chytrid hydrogenosomes (Fig. 9). Thus, all available evidence consistently shows that PFL, and not PFO, is one of the key enzymes in the hydrogenosomes of anaerobic chytrids. This discriminates the chytrid hydrogenosomes clearly from the hydrogenosomes of the parabasalids *Trichomonas vaginalis* and *Tritrichomonas foetus* (Steinbüchel and Müller, 1986; Müller, 1993) and the ciliate *Dasytricha ruminantium* (Yarlett *et al.*, 1982), the only other organisms in which the hydrogenosomal metabolism has

been studied in more detail. Because there is no simple answer to the question as to why hydrogenosomes of chytrids use a PFL instead of a PFO, one might speculate whether the descent and the evolutionary history of the anaerobic chytrids can provide arguments to understand the reasons for this important difference.

These anaerobic chytridiomycete fungi are unrelated to trichomonads and ciliates; phylogenetic analysis of their rRNA genes and biochemical and morphological evidence has shown unequivocally that they belong to the 'crown group' of eukaryotic microorganisms that secondarily adapted to an anoxic environment (Ragan and Chapman, 1978; Dore and Stahl, 1991; Sogin, 1991; Bowman *et al.*, 1992; Knoll, 1992; Li and Heath, 1992; Li *et al.*, 1993). Evidence has been presented that this adaptation involved a retargeting of mitochondrial enzymes such as the tricarboxylic acid cycle enzymes malate dehydrogenase and aconitase to the cytoplasm (Akhmanova *et al.*, 1998a; Fig. 10). As the acetohydroxyacid reductoisomerase is also located in the cytoplasm, one might even speculate as to whether anaerobic chytrids lost their mitochondria during their adaptation to anaerobic environments.

Phylogenetic analysis strongly suggests that *Piromyces*

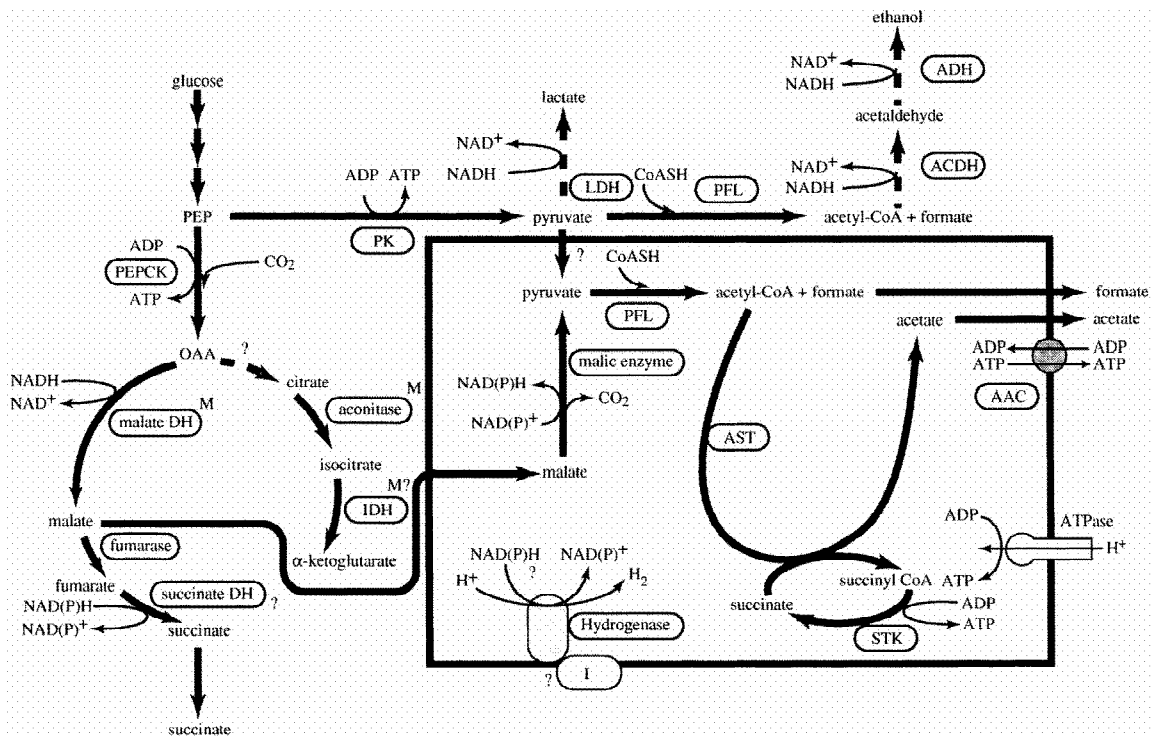

**Fig. 10.** Scheme of the glucose catabolic pathway in anaerobic chytrids (*Piromyces* sp. E2 and *Neocallimastix* sp. L2), based on the studies described previously by Marvin-Sikkema *et al.* (1993a; 1994), Akhmanova *et al.* (1998a) and present study. Box represents the hydrogenosome. Question marks indicate enzymes and transporters, the existence of which is uncertain. Abbreviations: PEP, phosphoenolpyruvate; OAA, oxaloacetate; PEPCK, phosphoenolpyruvate carboxykinase; malate DH<sup>M</sup>, malate dehydrogenase (of mitochondrial origin); also, for aconitase, superscript M indicates mitochondrial origin); succinate DH, succinate dehydrogenase; IDH<sup>M?</sup>, isocitrate dehydrogenase (origin uncertain); PK, pyruvate kinase; LDH, lactate dehydrogenase; PFL, pyruvate formate-lyase; ACDH, acetaldehyde dehydrogenase; ADH, alcohol dehydrogenase; AST, acetate:succinate CoA transferase; STK, succinate thiokinase; AAC, ATP/ADP carrier; (I), putative mitochondrial complex I-homologous hydrogenase subunits, which would allow direct NAD(P)H oxidation by the hydrogenase (Akhmanova *et al.*, 1998b)

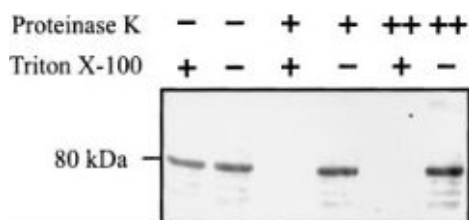

**Fig. 8.** Proteinase K protection assay with isolated hydrogenosomes. Hydrogenosomes were incubated in the absence (–) or presence of 0.2 (+) or 20 (++)  $\mu\text{g ml}^{-1}$  proteinase K and in the presence (+) or absence (–) of detergent (0.1% Triton X-100 and 0.1% deoxycholate). The Western blot was incubated with antiserum against PFL from *E. coli*.

was protected against digestion by proteinase K (Fig. 8). Addition of Triton X-100 to the hydrogenosomal fraction resulted in a complete digestion of the cross-reacting protein (Fig. 8). Consequently, PFL proteins must be located inside the hydrogenosome.

#### PFL activities in the hydrogenosomal and cytosolic fractions

Cellular fractionation and Western blotting revealed the presence of PFL in both the hydrogenosomes and the cytoplasm of *Piromyces* sp. E2 and *Neocallimastix* sp. L2. This subcellular localization has been confirmed by enzymatic measurements of PFL activity (Table 1). In the hydrogenosomes, PFL activity exceeded the activity in the cytoplasm by a factor of two. The specificity of the PFL assay has been tested; it was possible to inhibit the reaction completely by hypophosphite, a structural analogue of formate that acts as a suicide substrate (Plaga *et al.*, 1988).

Incubation of the hydrogenosomal fraction with pyruvate or malate, respectively, confirmed that the hydrogenosomes used malate, but not pyruvate for hydrogen formation. However, in contrast to the observations of Marvin-Sikkema *et al.* (1994), our measurements revealed that  $\approx 1$  mol of hydrogen was formed per 1 mol of malate utilized (Fig. 9; see also Marvin-Sikkema *et al.*, 1994). Because acetate and formate were also produced in equimolar amounts, a significant PFO activity in the hydrogenosomes could be excluded. However, only 0.7 mol of acetate and formate was formed per 1 mol of malate consumed. As a concomitant

**Table 1.** PFL activities in the cytosolic and hydrogenosomal fractions of *Piromyces* sp. E2.

	Enzyme activity ( $\mu\text{mol mg}^{-1}$ protein)	
	Cytosol	Hydrogenosomes
PFL	0.111	0.235
PFL + hypophosphite	ND	ND

PFL activity was measured by formate production after 60 min incubation at 39°C. Hypophosphite, a specific inhibitor of PFL activity, was added to a final concentration of 10 mM. ND, not detectable.

accumulation of pyruvate ( $\approx 0.3$  mol per 1 mol of consumed malate) has been observed (Fig. 9), the low product levels can be explained by the assumption that the PFL activity is rate limiting in isolated hydrogenosomes. Consequently, all data strongly support the assumption that PFL and not PFO is one of the key enzymes of the hydrogenosomal metabolism of chytrids.

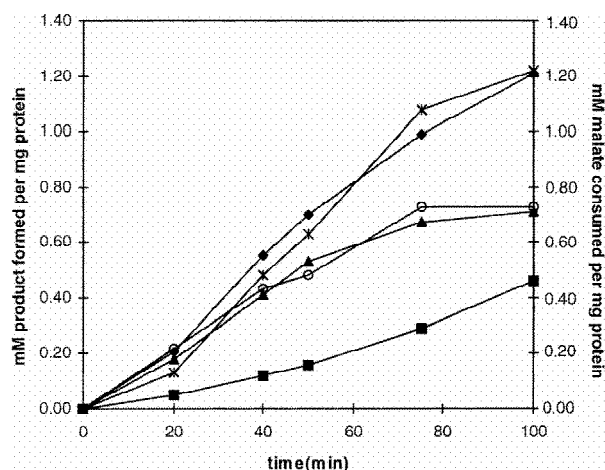

**Fig. 9.** Consumption of malate and production of hydrogen, acetate, formate and pyruvate by isolated *Piromyces* sp. E2 hydrogenosomes. Suspensions of isolated hydrogenosomes (aliquots containing  $\approx 0.55$  mg protein) were incubated anaerobically in the assay mixture (see *Experimental procedures*) at 39°C. Liquid samples (excreted products plus hydrogenosomal contents) were analysed for malate, pyruvate, acetate and formate. Gas samples were analysed by gas chromatography for the determination of the hydrogen concentration. The following symbols are used: ■ pyruvate; ▲ acetate; ○ formate; × hydrogen; ◆ malate.

#### Discussion

In this study, we have demonstrated for the first time that hydrogenosomes of anaerobic chytrids exhibit PFL activity, in contrast to all other hydrogenosomes that have been studied to date (Müller, 1993; Embley *et al.*, 1995; Biagini *et al.*, 1997). The presence of PFL in the hydrogenosomes of *Piromyces* sp. E2 and *Neocallimastix* sp. L2 has clearly been demonstrated by subcellular fractionation, Western blotting (Fig. 7), proteinase K protection assay (Fig. 8), measurements of enzyme activities (Table 1) and the fermentation patterns (Fig. 9). Northern and Western blotting have revealed that PFL genes are highly expressed in both species. We have shown that the *pfl* genes of *Piromyces* sp. E2 constitute a multigene family, which encodes 'long'- and 'short'-type PFLs. Both types are abundantly expressed, and it is likely that it is the 'long' type that encodes the hydrogenosomal PFLs. It remains to be shown that the N-terminal extension of 61 amino acids that is encoded by the 'long' PFL genes represents a hydrogenosomal targeting signal because the evidence that the extension might be cleaved off after import into

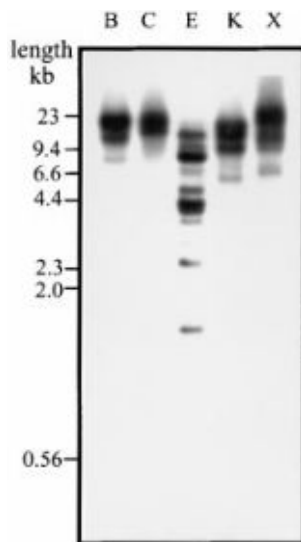
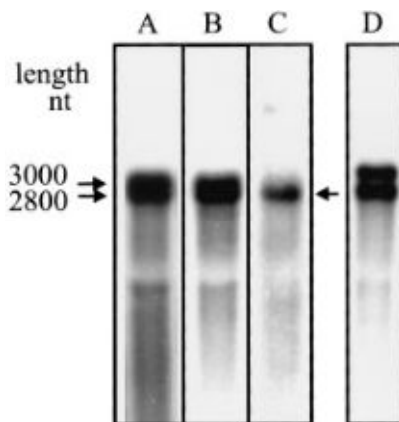

**Fig. 5.** Southern blot of genomic DNA from *Piromyces* sp. E2. Ten micrograms of genomic DNA digested with *Bam*HI (B), *Cl*al (C), *Eco*RI (E), *Kpn*I (K) and *Xba*I (X) was loaded per lane. cDNA clone pPFLa12, containing the 3' terminal part of the PFL-encoding gene, was used as probe. This probe does not contain restriction sites for the enzymes used for genomic DNA digestion.

Also, on Northern blots with RNA from a related anaerobic chytrid species, *Neocallimastix* sp. L2, two different transcripts could be readily detected using a *Piromyces* sp. E2 PFL probe (Fig. 6D). This suggests that abundant expression of *pfl* genes is a general feature of anaerobic chytrids.

#### Expression of PFL at the protein level

The subcellular localization of PFL in *Piromyces* sp. E2



**Fig. 6.** Analysis of PFL expression by Northern blotting. A. Northern blot with 10 µg of total RNA from *Piromyces* sp. E2, probed with the pPFLh115 clone. B. The same lane as in A, probed with the 5' part of the pL1 clone ('long'-type specific probe). C. The same lane as in A, probed with the 5' part of the pS2 clone ('short'-type specific probe). D. Northern blot with 1 µg of poly(A)<sup>+</sup> RNA from *Neocallimastix* sp. L2, probed with the pPFLh115 clone.

was investigated by cellular fractionation followed by Western blotting with an antiserum raised against pyruvate formate-lyase (PFLB) from *E. coli* (Conradt *et al.*, 1984; Rödel *et al.*, 1988). In both the hydrogenosomal and the cytosolic fraction of a homogenate of the mycelium, a double protein band with a molecular mass of ≈80–82 kDa was recognized by the antiserum (Fig. 7A). Such a doublet is characteristic for bacterial PFLs. It is the consequence of a specific fragmentation of the activated (free radical bearing) form of PFL in the presence of oxygen (Wagner *et al.*, 1992). The observed molecular mass of the hydrogenosomal PFL of *Piromyces* sp. E2 is 7 kDa lower than the predicted molecular mass of the 'long'-type PFL from *Piromyces* sp. E2 (89 kDa). This difference might be the consequence of a proteolytic processing of the 'long'-type PFL upon import into the hydrogenosomes

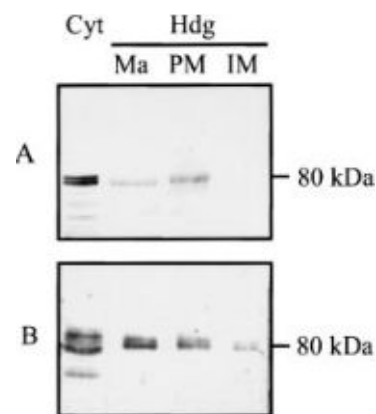

**Fig. 7.** Western blot analysis of the subcellular distribution of PFL. Western blotting of different subcellular fractions from *Piromyces* sp. E2 (A) and *Neocallimastix* sp. L2 (B). Cyt, cytosolic fraction. Hydrogenosomal fractions (Hdg) are indicated as follows: Ma, hydrogenosomal matrix; PM, peripheral membrane bound; and IM, integral membrane protein fraction. The antiserum used was directed against PFLB protein from *E. coli*.

because a removal of the putative N-terminal import signal from this isoform could account precisely for the observed difference. However, because we cannot exclude that the 'short'-type ('cytoplasmic') PFLs could also account for a cross-reacting protein with a molecular mass of ≈81 kDa (if the C-terminal part of the 'short' PFLs does not contain significant deletions or insertions), a confirmation of the hydrogenosomal localization is required.

Also in *Neocallimastix* sp. L2, a cross-reacting protein of the same size could be detected by Western blotting in both the cytosolic and the hydrogenosomal fractions (Fig. 7B). Also, in this chytrid species, part of the hydrogenosomal PFL appears to be membrane bound.

A proteinase K protection assay with isolated hydrogenosomes revealed that, in the absence of Triton X-100 (when the hydrogenosomal membranes are intact), PFL

A. 5' regions from different *Piromyces* sp. E2 PFL cDNA clones

pL1 -----  
 pL5 -----ATAAAAATAAGAAATTTACTTATTTGTAAAAACAAAAAAATCTTAATATACCAATAATATATGTGAAA  
 pL7 TAAATACCTTAAGGAATTTAAATAATCTTTATATACCAAAAAAACTGTGAATTATATATTTAAACAAACGCCAAATATATCTTTT  
 pS1 -----  
 pS2 -----

pL1 -----  
 pL5 -----ATAAAAATAAGAAATTTACTTATTTTACAAAAACAAAATAAAATCGAAAGCTTAACTTTAACTCRAAGTTAATAATGCTATGCGCAAGTCAGTTTCAGTT 86  
 pL7 TTATTAATAAAAAAACTTTTAAACAAAATCGAAAGCTTAACTTTAACTCRAAGTTAACAACGCTATGCGCAAGTCAGTTTCAGTT  
 pS1 -----  
 pS2 -----

pL1 -----  
 pL5 -----AACGCTGTTGCTGCCACCAAGGTCGCTGGTGTGAGAAATGGCAAGGCATCCCGCGCTCTTCACGCCAGCTATGAAGACTACT---CTT 173  
 pL7 AATGCTGTTGCTGCTACTAAAGTTCCTGGTGTAGAAATCAGCAAGGCATCCCGTGCATCCACACTACTCCAATGACTACGACTAGTCTT  
 pS1 -----  
 pS2 -----ATAAATACTAATTAATAATATGAGAAATTAATTTTTCATTAATTTTAAATAT

pL1 -----  
 pL5 -----AAGACTTCTAAGAAG-----GTCCCAGCTATGCAAGCTACGACTCAGGCCTCCATGCATCACCACAGATGCTGCTGCCAAG 257  
 pL7 AAGACTTCTAAGAAG-----GTCCAAGCTATGCAAGCTACGACTCAGGCCTCCATGCATCACCACAGATGCTGCTGCCAAG  
 pS1 TTTTATATATTTTAAATTTTAAACATATCAAAAATGTAATTTTAAATATTAAGTTATTTTAAATATATTAATATAAATAAAAACTG  
 pS2 TTTTATATATTTTAAATTTTAAACATATCAAAAATGTAATTTTAAATATTAAGTTATTTTAAATATATTAATATAAATAAAAACTG

pL1 -----  
 pL5 -----AGTGAATAATCGATGTTGAAGGTTGGATTAAAGAAGCACTACACCCATACGAAGGTGANGGTCTTTCCCT---GTGGTCCAACTGAAGAAG 344  
 pL7 AGTGAATAATCGATGTTGAAGGTTGGATTAAAGAAGCACTACACCCATACGAAGGTGANGGTCTTTCCCT---GTGGTCCAACTGAAGAA  
 pS1 CAAGTTATTCAGCTGCCAAGTGGATCAGCAAACTACACCCGATACGAAGGTGANGGTCTTTCCCTGTTACCGAAGCTTCTGCTAAG  
 pS2 CAAGTTATTCAGCTGCCAAGTGGATCAGCAAACTACACCCGATACGAAGGTGANGGTCTTTCCCTGTTACCGAAGCTTCTGCTAAG

B. 3' regions from different *Piromyces* sp. E2 PFL cDNA clones

h140 V L H I R  
 h115 D A M A H P E N Y P N L T I R V S G Y A V N F V K L T P

pPFLh115 GACGCGCTGGCCGCCCCAGAAAACATCCAAACCTTACTATTCCTTCTCTGCTTACCGCTGCAACTTTGCTTAAGTTAACGCCA 2402  
 pPFLh112 GATGCTATGCTCTATCCAGAAAATATCCAAACCTTACTATTCCTTCTCTGCTTACCGCTGCAACTTTGCTTAAGTTAACGCCA  
 pPFLh114 GATGCAATGGCCACATCCAGAAAATATCCAAACCTTACTATTCCTTCTCTGCTTACCGCTGCAACTTTGCTTAAGTTAACGCCA  
 pPFLh140 GATGCTATGCTCTATCCAGAAAATATCCAAACCTTACTATTCCTTCTCTGCTTACCGCTGCAACTTTGCTTAAGTTAACGCCA  
 pPFLh104 GATGCTATGCTCTATCCAGAAAATATCCAAACCTTACTATTCCTTCTCTGCTTACCGCTGCAACTTTGCTTAAGTTAACGCCA  
 pPFLa12 GACGCTATGGCCGCCCCAGAAAACATCCAAACCTTACTATTCCTTCTCTGCTTACCGCTGCAACTTTGCTTAAGTTAACGCCA

h140 D E K T L  
 h112, a12 A  
 h115 Q Q K E V I A R T F H E K M \*

pPFLh115 CAACAAACAAAGCAAGTTATGCGCCCTAGCTTCCACGAAAGAGAGTAATGCGCTTCAAAAAGTAATCTTTTGAACCACAAAGT 2486  
 pPFLh112 GCTCAACAAAGCAAGTTATGCTCTGCTTACCTTCCACGAAAGAGAGTAATGAAATAATATTTAATACTAGAAATATATTTAA  
 pPFLh114 CAACAAACAAAGCAAGTTATGCTCTGCTTACCTTCCACGAAAGAGAGTAATAAACAATAATCAAAATTTTATATATATAAACAA  
 pPFLh140 GACCAACAAAGCAAGTTATGCTCTGCTTACCTTCCACGAAAGAGAGTAATAGAGATTTAAAGGATATAAAAATTTGTTTACCATGA  
 pPFLh104 CAACAAACAAAGCAAGTTATGCTCTGCTTACCTTCCACGAAAGAGAGTAATTTGGAGAATTGTAATAAAAAAATAAAAAAAC--  
 pPFLa12 GCTCAACAAAGCAAGTTATGCTCTGCTTACCTTCCACGAAAGAGAGTAATATTT-----

pPFLh115 TTTTATCCACAAAAGTGTCTGAAAATCAGTGACCAATTTTTTAAACTTTTTTACTGGGTAAAAATTTTATATATAAAC 2570  
 pPFLh112 AGAAGAAATACTATCACCCTTTTATTTATTTTATTTTTTTTTTGGTGTTCAAAGAGGTAATAATATATAGTATACTCGAAAAAT  
 pPFLh114 TTAATAATATATATAAACATAAAAATGAAATGAAATATTAATAATTTAAATAAATTTAAATTAATAATCTTAATATAATGCTAA  
 pPFLh140 AAAATATATCAATTTTAAATAATTAATATAAATTTTATGAAAAATATATCATATAAATAATAGCCATCTCCAATCAACCAACA  
 pPFLh104 -----  
 pPFLa12 -----

pPFLh115 CATCCCTCCCAAAAATTTATAAATAGTAAAAGATTTTCTTTTATATTTAAAACATAAATTTTAAATATTTAAATTTTTTTT 2654  
 pPFLh112 AAAATAAAAATAAAAATAAAAATAAACGAATATACAATTTAATAAGCAACAACAACAACAACAATAATAATAAACA  
 pPFLh114 AATAAATTTAGCTTTTACAATAAAGAAAAAATTTATTTATAAATAAATAAATAAATAAATAAATAAATAAATAAATAAATAA  
 pPFLh140 CTATATAAATTTTATAATATAAATAAATAAATAAATAAATAAATAAATAAATAAATAAATAAATAAATAAATAAATAAATAA  
 pPFLh104 -----  
 pPFLa12 -----

pPFLh115 ATATAAATAAGTAAAAAATAAATGCAAAATATAAAAAAGTAAATAAATAAATAAATAAATAAATAAATAAATAAATAAATAAATAA 2733  
 pPFLh112 AATAAATAAACAATAAATAAATAAATAAATAAATAAATAAATAAATAAATAAATAAATAAATAAATAAATAAATAAATAAATAA  
 pPFLh114 ATACTATCAATAAAT-----  
 pPFLh140 TAGTTTAT-----  
 pPFLh104 -----  
 pPFLa12 -----

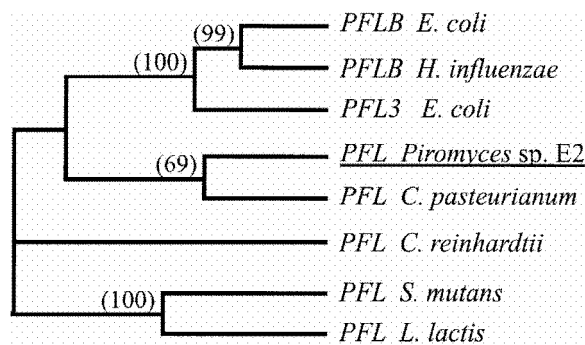

**Fig. 3.** Phylogenetic analysis of the C-terminal parts of the deduced PFL sequences by using the maximum likelihood method. C-terminal parts of the PFL sequences, corresponding to the sequence fragment available for *Chlamydomonas reinhardtii* (starting from amino acid residue 612 of *Piromyces* sp. E2 PFL-L1) were aligned with the program PILEUP and the alignment was refined by visual inspection. The best tree obtained by an exhaustive search using the PROTML program is shown. A tree with a similar topology was obtained with the neighbour-joining method. The numbers between brackets indicate the bootstrap values obtained for the same clades by using the neighbour-joining method. Database accession numbers are: *Clostridium pasteurianum*, Q46267 (Weidner and Sawers, 1996); *Chlamydomonas reinhardtii*, P37836 (Dumont et al., 1993); *E. coli* PFLB, P09373 (Rödel et al., 1988); *E. coli* PFL3, P42632 (Blattner et al., 1997; Hesslinger et al., 1998); *E. coli* PFLD, P32674 (Blattner et al., 1993; Reizer et al., 1995); *Haemophilus influenzae*, P43753 (Fleischmann et al., 1995); *Streptococcus mutans*, Q59934 (Yamamoto et al., 1996); *Lactococcus lactis*, AJ000326 (Arnau et al., 1997).

observed in the non-coding 5' and 3' UTRs (Fig. 4). In the coding regions, many synonymous, but also a few non-synonymous, substitutions were present (Figs 2A and 4). Our data strongly suggest that the genome of *Piromyces* sp. E2 possesses multiple, non-identical genes that encode several putative PFL isoforms. This assumption has been confirmed by Southern blotting of genomic DNA from *Piromyces* sp. E2 (Fig. 5). Because the PFL probe that was hybridized to the blot did not contain restriction sites for the enzymes that had been used for the digestion of the genomic DNA, the multiple bands observed on the blot argue for the presence of multiple copies of *pfl* genes. It is unlikely that restriction sites in introns contributed significantly to the complex pattern of restriction fragments because introns in the genome of *Piromyces* sp. E2 are rare and small (F. Voncken and H. Harhangi, unpublished).

**Fig. 4.** Multiple alignments of the 5' terminal (A) and the 3' terminal (B) nucleotide sequences of different putative PFL-encoding cDNA fragments from *Piromyces* sp. E2. Coding sequences are shown in bold. The numbering corresponds to the nucleotide positions in the composite cDNA sequence PFL-L1. Nucleotides identical in all sequences are shaded with dark grey. Additionally, nucleotides conserved in more than 60% of the sequences are shaded with light grey in A. In B, the encoded amino acids (derived from the clone pPFLh115) are shown above the nucleotide alignment. The amino acids encoded by clones pPFLa12, pPFLh112 and pPFLh140, which are different from those encoded by pPFLh115, are also indicated. The start codon (ATG) is marked by a bent arrow, whereas the stop codon is marked with an asterisk. The sequence data have been submitted to the DDBJ/EMBL/GenBank databases under the accession numbers Y16739 (composite cDNA PFL-L1); Y16738 (clone pS2); Y16740 (clone pPFLh104); Y16741 (clone pL7); Y16742 (clone pPFLh114); Y16744 (clone pS1); Y16745 (clone pPFLh112); Y16746 (clone pPFLa12); Y16749 (clone pPFLh140); and Y16750 (clone pL3).

Because the *pfl-11* gene of *Piromyces* sp. E2 encodes an N-terminal extension that might function as a hydro-genosomal import and targeting signal, the question arose as to whether all *pfl* genes encode such an N-terminal extension or whether some of the *pfl* genes lack such an N-terminus. The latter ones might encode a cytoplasmic PFL, which has been postulated by Marvin-Sikkema et al. (1993a). Therefore, we performed a 5' RACE-PCR with the primer PFLrev2 (see Fig. 1) to identify genes with and without an N-terminal extension. In addition to clones identical to pL1 (possessing the N-terminal extension), two shorter clones (pS1 and pS2) were identified that lacked the first 74 N-terminal amino acids encoded by pL1 (Fig. 2A). Moreover, they differed from each other by four nucleotide substitutions (one of them non-synonymous) (Figs 2A and 4A). Comparison of the pS1 clone as a representative of the 'short'-type PFL with the pL1 clone (a representative of the 'long'-type PFL) revealed a 58.2% identity at the protein level. Thus, it has to be concluded that a multigene family, encoding two types of PFL (e.g. 'short'- and 'long'-type PFL), is present in the genome of *Piromyces* sp. E2. Here, we have identified two clones coding for the 'short'-type PFLs, which differed from each other by one amino acid substitution, and three clones encoding the 'long'-type PFLs, which differed from each other by several amino acid substitutions and insertions/deletions (see Fig. 2A).

#### Expression of *pfl* genes at the mRNA level

The transcription of the *pfl* genes of *Piromyces* sp. E2 was investigated by Northern blotting (Fig. 6). Two transcripts of 2800 and 3000 nucleotides, respectively, were observed on the Northern blot when the clone pPFLh115 was used as a probe (Fig. 6A). To investigate whether the two transcripts correspond to the 'long' and 'short' type of PFL, the probes derived from the 5' terminal parts of the clones pL1 ('long' type) and pS2 ('short' type) were hybridized to the same Northern blot lanes. The 'long'-type probe hybridized to both transcripts, obviously as a result of a length polymorphism at the 3' end (see Fig. 4B). The 'short'-type probe hybridized only to the 2800 nt long mRNA (Fig. 6B and C). Consequently, it must be concluded that both the 'long' and the 'short' types of *pfl* genes are abundantly expressed.

A. PFL N-termini

Piromyces pL1	MESLALSNSVS-VLANTVSVNAVAATKVAGVRMAKPSRALHTPAMKTT-LKTSKK--VPAMQAKTYATQAPC	67
Piromyces pL5	MESLPLTQVNNAIAKSVSVNAVAATKVAGVRISKPSRAIHTTPMTTTTSLKTSKSSFPSIQTKTYATQAPC	71
Piromyces pL7	MESLTLTQVNNAIAKSVSVNAVAATKVAGVRISKPSRAMHTTPMTTTTSLKTSK---VQAMQAKTYATQAPC	68
Piromyces pS1	-----	-
Piromyces pS2	-----	-
C. pasteurianum	-----MFKQWE	6
H. influenzae	-----SELNEMQKLAWA	12
E.coli PFLB	-----SELNEKLATAWE	12
E.coli TdcE	-----MKVDIDTSDKLYADAWL	17
S. mutans	-----MATVKTNTDVFEEKAWA	16
L. lactis	-----MKTEVTE-NIFEQAWD	15
Piromyces pL1	ITNDAAAKSEIDVEGWIKKHHTPYEGDGS <b>SFL</b> -AGPTEKTKKLFKAKEEYLAKERANGGLYD <b>VDP</b> PHTPSTI	136
Piromyces pL5	ITSDAAAKSEIDVEGWIKKHHTPYEGDGS <b>SFL</b> -AGPTEKTKKLFKAKEEYLAKERANGGLYD <b>VDP</b> PHTPSTI	140
Piromyces pL7	ITNDAAAKSEIDVEGWIKKHHTPYEGDGS <b>SFL</b> -SCPTEKTKKLFKAKEEYLAKERANGGLYD <b>VDP</b> PHTPSTI	137
Piromyces pS1	-----MQVIDVAKWIKENYTPYEGDAS <b>SFL</b> VTDASAKTKDVMNKCCELRAEEIKTNGCLD <b>VDP</b> NKTIISTV	63
Piromyces pS2	-----MQVIDVAKWIKENHTPYEGDAS <b>SFL</b> VTDASAKTKDVMNKCCELRAEEIKTNGCLD <b>VDP</b> NKTIISTV	63
C. pasteurianum	GFQDGEWTNDVNRDFIQKNYKEYTQDK <b>SFL</b> -KCPTEKTKKLVMDKAVSLILEE-LKKGILD <b>VDP</b> TETISGI	74
H. influenzae	GFAGGDWQENYNVRDFIQKNYTPYEGD <b>SFL</b> -AGPTEATTKLWESVMEGIKLENRTHAPL <b>D</b> DEHTPSTI	81
E.coli PFLB	GFTKGDWQENYNVRDFIQKNYTPYEGD <b>SFL</b> -AGATEATTLWDKVMEGVKLENRTHAP <b>VDP</b> DTAVASTI	81
E.coli TdcE	GFKGTDWKNEENVRDFIQHNYTPYEGD <b>SFL</b> -AEATPATTELWEKVMGIRIENATHAP <b>VDP</b> DTNIATTI	86
S. mutans	GFKGTDWKDRASISRFVQDNVTPYDGG <b>SFL</b> -AGPTERSLHKKVVEET--KAHYEETRF <b>PMD</b> -RITSI	82
L. lactis	GFKGTNWRDKASVTRFVQENYKPYD <b>GD</b> <b>SFL</b> -AGPTERTLKVKKI <b>IED</b> --KNHYEEVGF <b>PPD</b> DTDRVTSI	82

B. PFL C-termini

Piromyces PFL-L1	LLD <b>G</b> YF <b>T</b> KG-----AH <b>HLN</b> V <b>N</b> VLK <b>R</b> ETL <b>E</b> DA <b>MA</b> HPENYPNLT <b>IRV</b> <b>SG</b> YAVNFVKLTP <b>Q</b> Q <b>Q</b> KEVIA	747
C. reinhardtii	ILD <b>G</b> Y <b>F</b> ANG-----GH <b>HLN</b> V <b>N</b> VLN <b>R</b> SM <b>L</b> MD <b>AV</b> EHPEKYPNLT <b>IRV</b> <b>SG</b> YAVHFARLT <b>R</b> EQ <b>Q</b> LEVIA	188
C. pasteurianum	IM <b>G</b> Y <b>F</b> G <b>Q</b> G-----AH <b>HLN</b> V <b>N</b> VLN <b>R</b> ETL <b>I</b> DA <b>MN</b> NPDKYPTL <b>IRV</b> <b>SG</b> YAVNFNRLSKDHQ <b>Q</b> KEVIS	733
H. influenzae	LMD <b>G</b> Y <b>F</b> HHEAT <b>V</b> EG---G <b>HLN</b> V <b>N</b> VLN <b>R</b> EM <b>L</b> DA <b>MEN</b> PDKY <b>P</b> QLT <b>IRV</b> <b>SG</b> YAVRFNSLT <b>K</b> EQ <b>Q</b> Q <b>D</b> VIT	762
E.coli PFLB	LMD <b>G</b> Y <b>F</b> HHEAS <b>I</b> EG---G <b>HLN</b> V <b>N</b> VLN <b>R</b> EM <b>L</b> DA <b>MEN</b> PEKYP <b>Q</b> LT <b>IRV</b> <b>SG</b> YAVRFNSLT <b>K</b> EQ <b>Q</b> Q <b>D</b> VIT	752
E.coli TdcE	ILD <b>G</b> Y <b>F</b> HHEAD <b>V</b> EG---G <b>HLN</b> V <b>N</b> VLN <b>R</b> EM <b>L</b> DA <b>IE</b> HPEKYPNLT <b>IRV</b> <b>SG</b> YACASTH-----	744
S. mutans	ILD <b>G</b> Y <b>F</b> EGG-----G <b>HLN</b> V <b>N</b> VLN <b>R</b> MDLKD <b>V</b> Y <b>D</b> KIMNGE---DV <b>I</b> <b>V</b> <b>R</b> <b>I</b> <b>S</b> <b>G</b> Y <b>C</b> VNTKYLT <b>K</b> EQ <b>Q</b> TEL <b>T</b> Q	755
L. lactis	ILD <b>G</b> Y <b>F</b> TPGALINGTEFAG <b>OH</b> V <b>N</b> VLN <b>R</b> MDLKD <b>V</b> Y <b>D</b> KIMRGE---DV <b>I</b> <b>V</b> <b>R</b> <b>I</b> <b>S</b> <b>G</b> Y <b>C</b> VNTKYLT <b>P</b> EQ <b>Q</b> EL <b>T</b> E	767
Piromyces PFL-L1	RT <b>F</b> HEKM-----	754
C. reinhardtii	RT <b>F</b> HDTM-----	195
C. pasteurianum	RT <b>F</b> HEKL-----	740
H. influenzae	RT <b>F</b> TESM-----	769
E.coli PFLB	RT <b>F</b> TQSM-----	759
E.coli TdcE	-----	-
S. mutans	R <b>V</b> FHEVLSMD <b>DA</b> ATDLV <b>NN</b> K	775
L. lactis	R <b>V</b> FHEVLSND <b>DE</b> VM <b>H</b> TS <b>N</b> I	787

Fig. 2. Multiple alignments of the deduced N-terminal (A) and C-terminal (B) sequences of different putative PFL enzymes. Amino acids identical in all sequences are in bold and shaded with dark grey. Amino acids similar in more than 70% of the sequences are shaded with light grey. For database accession numbers, see legend to Fig. 3. Glycine residue, involved in catalysis (Wagner *et al.*, 1992) is underlined.

represent a hydrogenosomal targeting signal (see Brondijk *et al.*, 1996; van der Giezen *et al.*, 1997; 1998).

The high similarity between PFL-L1 of *Piromyces* sp. E2 and the PFL-encoding genes of the various eubacteria, including *Escherichia coli*, *Clostridium*, *Streptococcus* and *Lactococcus* (Rödel *et al.*, 1988; Weidner and Sawers, 1996; Yamamoto *et al.*, 1996; Arnau *et al.*, 1997), suggests a prokaryotic rather than an eukaryotic origin. A pairwise comparison of the C-terminal parts of different PFL enzymes strongly supports this interpretation. Therefore, it is not surprising that phylogenetic analyses using neighbour-joining, parsimony or maximum likelihood methods revealed that the two eukaryotic sequences known to date

(*Piromyces* sp. E2 and *Chlamydomonas reinhardtii*) do not form a separate clade (Fig. 3).

*PFL proteins of Piromyces sp. E2 are encoded by a multigene family*

All six cDNA clones obtained by random sequencing of the cDNA library (i.e. pPFLh104, pPFLh112, pPFLh114, pPFLh115, pPFLh140 and pPFLa12; see Fig. 1) were different (Fig. 4B). Also, the clones pL5, pL6 and pL7 (see Fig. 1), representing the 5' part of PFL cDNAs, differed at multiple positions from the PFL-L1 sequence (Fig. 4A). The majority of the sequence differences were

Because intensive attempts to isolate chytrid genes encoding PFO with the aid of PCR techniques have failed, we constructed a cDNA library using mRNA from rapidly growing, hydrogen-producing cultures of the anaerobic chytrid *Piromyces* sp. E2. We anticipated that genes encoding hydrogenosomal enzymes must be highly expressed under conditions in which maximum hydrogen production is observed (Teunissen *et al.*, 1991). DNA sequencing of 90 randomly chosen clones of this cDNA bank failed to identify any PFO gene but 6 out of the 90 clones exhibited a substantial homology to prokaryotic pyruvate formate-lyase (PFL), another pyruvate-converting enzyme. Here, we show that mRNAs encoding putative PFLs are abundantly expressed, and that PFL activity can be detected in the hydrogenosomes of *Piromyces* sp. E2. We show also that the fermentation patterns of isolated hydrogenosomes support the assumption that PFL and not PFO is one of the key enzymes of the hydrogenosomal metabolism of anaerobic chytrids. We will discuss a potential eubacterial origin of the PFL of anaerobic chytrid fungi and its bearing for a potential polyphyletic origin of the hydrogenosomes.

## Results

### Isolation of PFL-encoding cDNAs from the *Piromyces* sp. E2 cDNA library

Ninety clones, randomly chosen from a *Piromyces* sp. E2 cDNA library that has been described earlier (Akhmanova *et al.*, 1998a), were partially sequenced. Among these cDNAs, six clones (named pPFLh104, pPFLh112, pPFLh114, pPFLh115, pPFLh140 and pPFLa12; see Fig. 1) displayed a high degree of similarity to pyruvate formate-lyase (PFL)-encoding genes from different eubacteria. The longest of these cDNAs (pPFLh115) was sequenced completely. It contained an open reading frame (ORF) of 2040 bp, which could be aligned over the whole length with a *pfl* gene of *Clostridium pasteurianum* (Weidner and Sawers, 1996). However, the absence of an AT-rich 5' untranslated region (UTR) that is characteristic for genes of anaerobic chytrids (Durand *et al.*, 1995; Fanutti *et al.*, 1995; unpublished observations of the authors) and the lack of a translation start codon indicated that the pPFLh115 cDNA was incomplete.

To obtain the 5' part of this cDNA, we performed a 5' rapid amplification of cDNA ends PCR (RACE-PCR) with the primers PFLrev1 or PFLrev3 (see Fig. 1). With the primer PFLrev1, three clones (pL1, pL2 and pL3) were isolated. DNA sequence analysis of these clones revealed an exact match with the clone pPFLh115 over a contiguous stretch of 811 bp. Consequently, the clones pL1, pL2, pL3 and pPFLh115 must be derived from the same gene. Also, one of the clones (pL4) that were

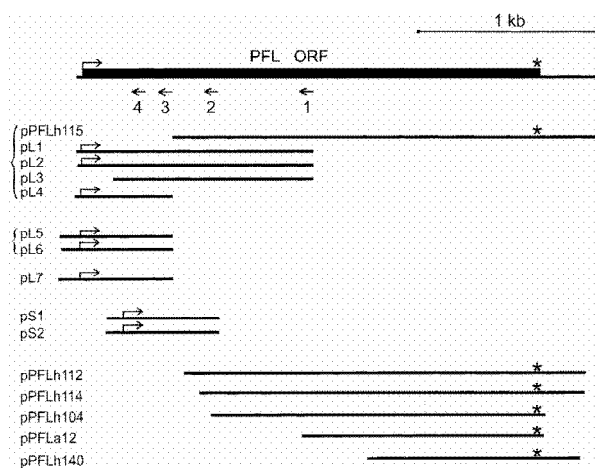

**Fig. 1.** PFL-encoding cDNA clones from *Piromyces* sp. E2. The scheme of the composite cDNA sequence PFL-L1 (assembled from clones pL1 and pPFLh115) is shown at the top, with the black box indicating the open reading frame. cDNA clones, identified by random screening (designated pPFL) or isolated by 5' RACE (the rest of the clones) are shown by thick lines. Short thick arrows indicate the position of the PFL-specific primers PFLrev1 to PFLrev4 (marked 1–4) used in this study. Thin bent arrows indicate the positions of the first ATG codon, and the asterisks indicate the position of the stop codon. Groups of clones, identical in the overlapping regions, are marked with curly brackets.

obtained with the primer PFLrev3 must be derived from this *pfl* gene. However, the clones pL5, pL6 and pL7 (also obtained with the primer PFLrev3; see Fig. 1) differed in several positions and must be derived from different *pfl* genes.

A complete gene encoding a putative PFL ('PFL-L1') was reconstructed from the clones pPFLh115 and pL1. The gene contained an ORF encoding a protein of 805 amino acids with a predicted molecular mass of 89 kDa. At the amino acid level, the predicted protein exhibited a substantial similarity with the PFL of *Clostridium pasteurianum* (77% similarity and 61% identity). The amino acids that are involved in catalysis, for example the neighbouring cysteines in the middle part of the protein (Knappe and Sawers, 1990) and the glycine residue near the C-terminus (Wagner *et al.*, 1992; see Fig. 2B), are conserved. Also, the C-terminus of PFL-L1 exhibits a high degree of similarity to the C-terminus of the *Clostridium pasteurianum* PFL (Fig. 2B). The N-termini, in contrast, are rather divergent.

Alignment of PFL-L1 with the deduced *Clostridium pasteurianum* PFL sequence revealed that the chytrid sequence possesses a N-terminal extension of 61 amino acids (Fig. 2A). This N-terminal extension is enriched in positively charged and hydroxylated amino acids. Because such an amino acid composition is similar to that of mitochondrial transit peptides (Hendrick *et al.*, 1989; von Heijne *et al.*, 1989), the N-terminal extension of PFL-L1 might

# A hydrogenosome with pyruvate formate-lyase: anaerobic chytrid fungi use an alternative route for pyruvate catabolism

Anna Akhmanova,<sup>†‡</sup> Frank G. J. Voncken,<sup>‡</sup> Ken M. Hosea, Harry Harhangi, Jan T. Keltjens, Huub J. M. op den Camp, Godfried D. Vogels and Johannes H. P. Hackstein\*

Department of Microbiology and Evolutionary Biology, Faculty of Science, University of Nijmegen, Toernooiveld, 6525 ED Nijmegen, The Netherlands.

## Summary

The chytrid fungi *Piromyces* sp. E2 and *Neocallimastix* sp. L2 are obligatory amitochondriate anaerobes that possess hydrogenosomes. Hydrogenosomes are highly specialized organelles engaged in anaerobic carbon metabolism; they generate molecular hydrogen and ATP. Here, we show for the first time that chytrid hydrogenosomes use pyruvate formate-lyase (PFL) and not pyruvate:ferredoxin oxidoreductase (PFO) for pyruvate catabolism, unlike all other hydrogenosomes studied to date. Chytrid PFLs are encoded by a multi-gene family and are abundantly expressed in *Piromyces* sp. E2 and *Neocallimastix* sp. L2. Western blotting after cellular fractionation, proteinase K protection assays and determinations of enzyme activities reveal that PFL is present in the hydrogenosomes of *Piromyces* sp. E2. The main route of the hydrogenosomal carbon metabolism involves PFL; the formation of equimolar amounts of formate and acetate by isolated hydrogenosomes excludes a significant contribution by PFO. Our data support the assumption that chytrid hydrogenosomes are unique and argue for a polyphyletic origin of these organelles.

## Introduction

Hydrogenosomes are membrane-bound organelles found in a wide variety of unicellular anaerobic eukaryotes. These protists belong to phylogenetically rather unrelated groups,

and it is likely that their hydrogenosomes evolved several times in different, phylogenetically disparate lineages (Embley *et al.*, 1995; Martin and Müller, 1998). Hydrogenosomes metabolize pyruvate or malate to hydrogen, acetate and CO<sub>2</sub>, and they are characterized by their key enzymes hydrogenase and pyruvate:ferredoxin oxidoreductase (PFO) (Yarlett *et al.*, 1986; O'Fallon *et al.*, 1991; Marvin-Sikkema *et al.*, 1993a; Müller, 1993; Trinci *et al.*, 1994). However, our knowledge about hydrogenosomes is mainly based on studies carried out over the last decade of the hydrogenosomes of *Trichomonas vaginalis* and its relatives, and it cannot be excluded that the hydrogenosomes of the various protists have deviating properties (Müller, 1993; Coombs and Hackstein, 1995).

There is evidence that the hydrogenosomes of anaerobic chytrids are different; their ultrastructure exhibits a number of traits that discriminates them clearly from the hydrogenosomes of *Trichomonas* (Yarlett *et al.*, 1986; Marvin-Sikkema *et al.*, 1993a,b; Benchimol *et al.*, 1996a,b). Moreover, it has been claimed that – in contrast to *Trichomonas* – the hydrogenosomes of chytrids rely on malate rather than pyruvate for their metabolism (Marvin-Sikkema *et al.*, 1994). Also, the evidence for PFO activity in the hydrogenosomes of chytrids is poor. Notwithstanding that hydrogenosomes of chytrids possess a highly active hydrogenase, only low levels of PFO activity were measured in the hydrogenosomal fraction of these cells by Marvin-Sikkema *et al.* (1993a). Measurements of fermentation products of isolated hydrogenosomes seemed to support the assumption that PFO is a key enzyme in the hydrogenosomes of the chytrid *Neocallimastix*, similar to the situation in the hydrogenosomes of the parabasalid *Trichomonas*. However, formation of CO<sub>2</sub> by isolated hydrogenosomes could not be detected, although the formation of 2 mol of CO<sub>2</sub> per mol of malate utilized had been postulated (Marvin-Sikkema *et al.*, 1994). Moreover, also the formation of substantial amounts of formate by the axenic cultures of the chytrids *Neocallimastix* sp. L2 and *Piromyces* sp. E2 (Marvin-Sikkema *et al.*, 1992; F. G. J. Voncken, unpublished) was in conflict with the metabolic scheme that had been postulated (Marvin-Sikkema *et al.*, 1993a; 1994). Because of these puzzling results, only an alternative, molecular genetic approach in combination with biochemical techniques promised a chance to unravel the elusive metabolism of chytrid hydrogenosomes.

Received 26 November, 1998; revised 28 February, 1999; accepted 19 March, 1999. †Present address: Department of Cell Biology and Genetics, Erasmus University, PO Box 1738, 3000 DR Rotterdam, The Netherlands. ‡These authors contributed equally to this study. \*For correspondence. E-mail hack@sci.kun.nl; Tel. (+31) 24 3652935; Fax (+31) 24 3553450.